

TECTON



Active Light | Connecting with Nature

Creating Light Creates Precision

01:00 02:00 03:00 04:00 05:00 06:00 07:00 08:00 09:00 10:00 11:00 12:00

Active Light in industry is as unique and dynamic as the employees, the processes and the layout of different production halls. Human Centric Lighting puts the focus of the lighting design firmly on the individual. Visual, emotional and biological needs are fully supported by a blend of Active Light and additional workplace-oriented lighting for work during the day and the night. This approach also facilitates accurate working and improved quality. Pioneering lighting solutions with activity-based lighting use innovative sensor technology to automatically adapt to the specific situation.

Find out how Active Light works:
zumtobel.com/activelight



Intensity

Dynamically adjusted lighting levels help employees with their regular visual tasks. Active Light helps reduce error rates and increase worker safety.



Direction

Uniform and shadow-free illumination minimises glare – even with glossy surfaces. Adjusting the direction of the light towards the visual object with Active Light enhances visual quality. Precise work is promoted and fatigue is simultaneously kept to a minimum.



Colour

Active Light means tailoring light colours to reflect age, user preference and working hours, increasing well-being and boosting employee productivity.



Time

Artificial light based on the natural course of the day helps support the internal clock. Luminaires controlled by sensors, which only switch on when light is required, reduce costs and minimise energy consumption.

TECTON

The universal LED continuous-row system



Exhibition halls 9 to 12, Dornbirn | AT

Architects: Marte.Marte Architekten ZT GmbH, Feldkirch | AT

Lighting Solution Partner: Graf Elektronik GmbH, Dornbirn | AT





HAWE Hydraulik, Kaufbeuren | DE

Architecture: Barkow Leibinger Architekten, Berlin | DE

Lighting design: Christian Kaindl Elektroplanung, Nandlstadt | DE



Eurospar Schwefel, Dornbirn | AT

Architecture: Dipl. Ing. Christian Lenz ZT GmbH, Schwarzach | AT

Electrical consultants: Müllner Energieberatung & Haustechnik GmbH, Dornbirn | AT





Aperitif
Kräuterbitter

Wodka
Mixgetränke

Brände

AKTUELL!
2,99

PROSECCO
D.O.C.

Contents 6 Bottles
0,75 Lt

Contents 6 Bottles
0,75 Lt

PROSECCO
D.O.C.

PROSECCO
D.O.C.

Contents 6 Bottles
0,75 Lt

Contents 6 Bottles
0,75 Lt

CAMPARI
BILLIGER!
12,99



AKTUELL!
1,99



JUL

PROSECCO
D.O.C.

Mischarchiv (2x 20 ml)

6

6

6

6

6

6

6

6

6

6

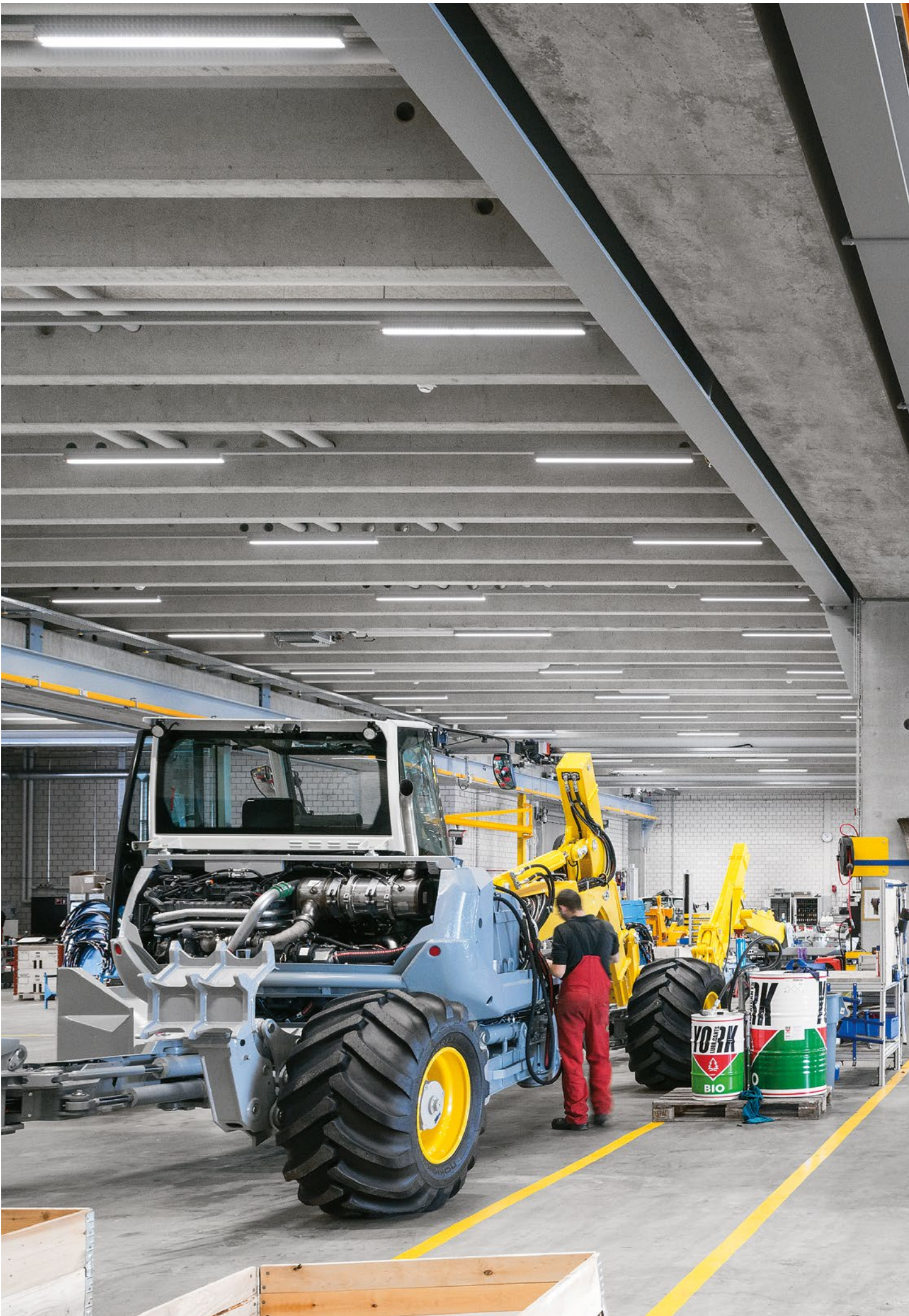

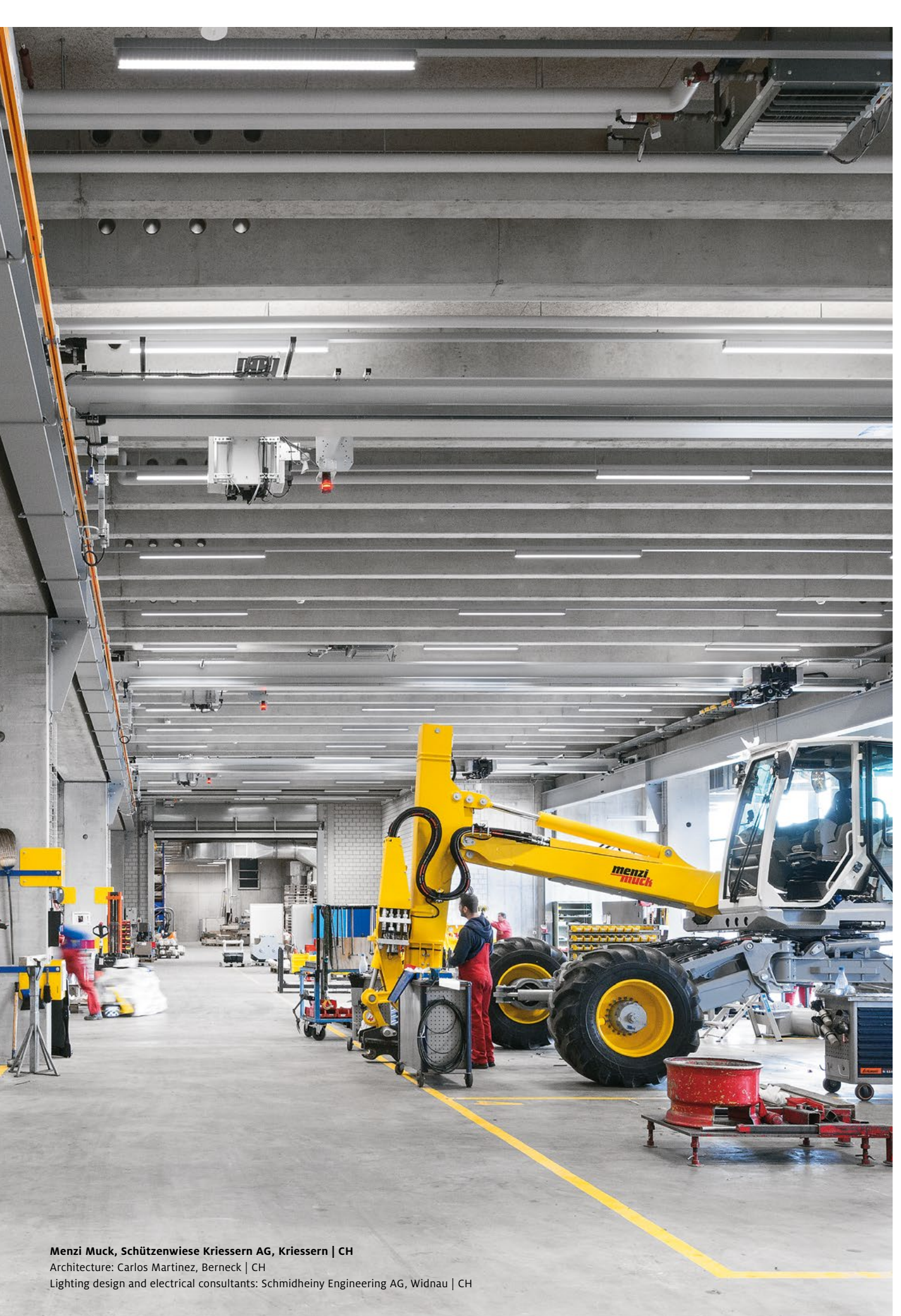

Menzi Muck, Schützenwiese Kriessern AG, Kriessern | CH

Architecture: Carlos Martinez, Berneck | CH

Lighting design and electrical consultants: Schmidheiny Engineering AG, Widnau | CH

System overview

TECTON continuous-row lighting system

1 Trunking

Page 14

2 Continuous-row luminaire

Page 22

3 Office and industrial luminaires

Page 42

4 Spotlights

Page 46

5 Emergency lighting

Page 48

6 Lighting management

Page 54



Trunking



Electric feed

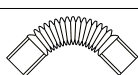

Flexible connector

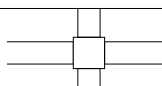

Node connector



TECTON
with split-lens
technology



TECTON
with integrated
smart location



TECTON MIREL
with MIREL lens optic



TECTON MPO
with micro-
prismatic optic



TECTON BASIC
with diffuser optic

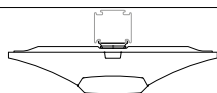

MELLOW LIGHT
surface-mounted
luminaire for office
applications

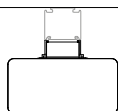

ECOOS
micro-pyramidal
optic

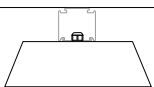

CRAFT
high-bay luminaire



PERLUCE
moisture-proof
luminaire



LINCOR
surface-mounted
luminaire for office
applications

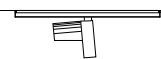

INTRO
spotlight

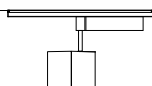

VIVO
spotlight

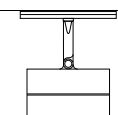

ONICO
spotlight

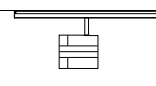

FACTOR
spotlight

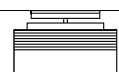

KATALYST
spotlight



RESLITE PRO escape
escape-route lighting



RESLITE PRO spot
object lighting



RESLITE PRO antipanic
anti-panic lighting



PURESIGN 150
escape-sign luminaire

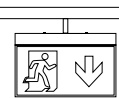

CROSSIGN 110/160
escape-sign luminaire



ED-SENS
presence detector



ED-EYE
daylight sensor



PST
presence detector



LITECOM
lighting
management



DIMLITE
lighting
management

1 Trunking

The floating base

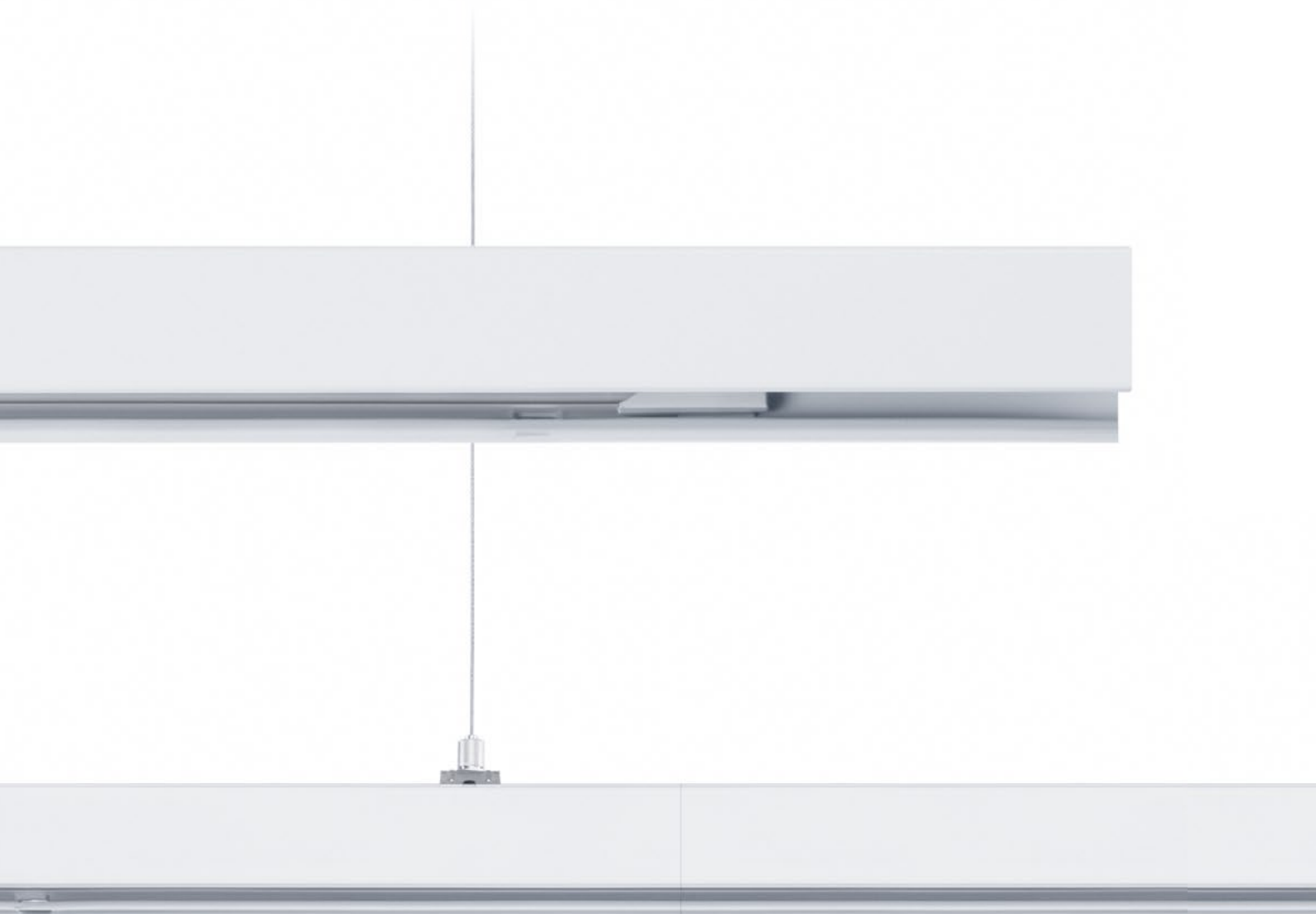

With an 11-pole current-conducting section built into the trunking, this system comes ready equipped to meet tomorrow's needs. All functions such as power supply, lighting control and connection to emergency lighting are seamlessly integrated into this multifunctional trunking. Luminaires can be positioned flexibly and the system can be adapted to suit structural alterations at any time. TECTON copes effortlessly with various lighting requirements – at the time it is installed and whenever there are changes. The TECTON trunking remains unchanged and forms the functional backbone of the system. It is simply a matter of exchanging or adding luminaires and system components.



-55%

In a comparison of eight different continuous-row LED systems regarding the time required for installation of a continuous-row solution (15 m), independent refaconsult GmbH found that TECTON can be installed considerably faster than comparable products.

1 Trunking

Versatile. Flexible. Time-saving.

5 connections for power supply (5 x 2.5 mm²)

- Load sharing allows triple continuous-row length
- Separately switchable circuits for extremely easy light control in triple circuit

4 poles for two independent emergency lighting circuits (4 x 1.5 mm²)

- Two independent emergency lighting circuits allow optimal integration of emergency lighting into general lighting
- High degree of design reliability, flexibility and adaptability after commissioning

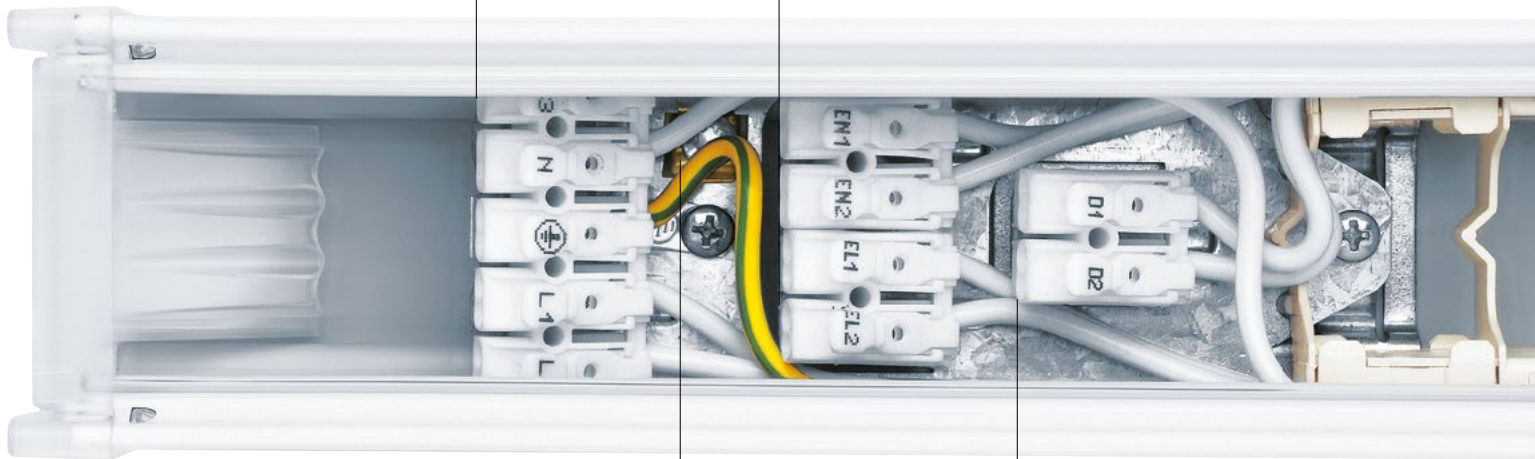

TECTON TE feed-in | 1:1 scale

2. Terminal for conductor

- An additional terminal offers the chance to connect more conductors

2 control lines with DALI control signal for brightness control (2 x 1.5 mm²)

- Efficient, flexible, customised lighting for industrial and commercial buildings
- Purposefully staged lighting scenes in shops and retail areas
- Intelligent lighting management system reports all faults (e.g. electronic ballast or lamp failure)



Surface in white, silver or black

- Roll-formed sheet steel with option of white, silver or black polyester resin enamel finish



white



silver



black

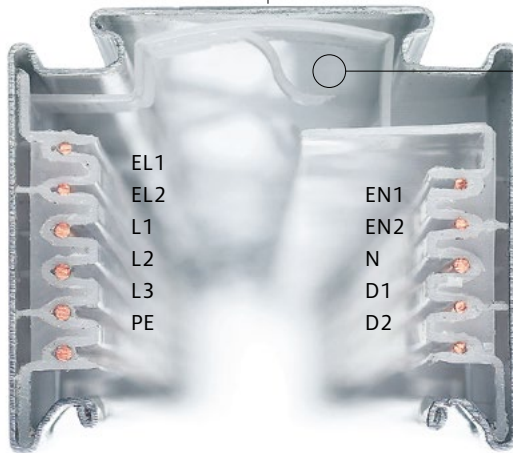

Optional cable duct

- Additional cable duct for running cable on rear side
- No adverse effect on trunking suspension

Cable duct

- Additional cable can be accommodated if required

1:1 scale

Patented butt-joint connector for fast and easy mounting without any additional components

- Complete flexibility as power can be tapped into over the entire length of the track
- Preassembled connector makes it possible to install the continuous row without having to use any other tools or equipment
- Electrical and mechanical connection with a simple flick of the wrist

1 Trunking

Node connector

Using various node connectors, the TECTON continuous-row lighting system can be assembled and combined in a myriad of variants, fully meeting the respective requirements in terms of design and lighting technology. TECTON L-, T-, X- and flexible connectors open up many different options for creative design using light. Thus, the structures themselves become integral parts of the interior design. The electrical engineer will define the wiring sequence via the node connectors on site, depending on the application requirements.

TECTON node connector TECTON T-VT2

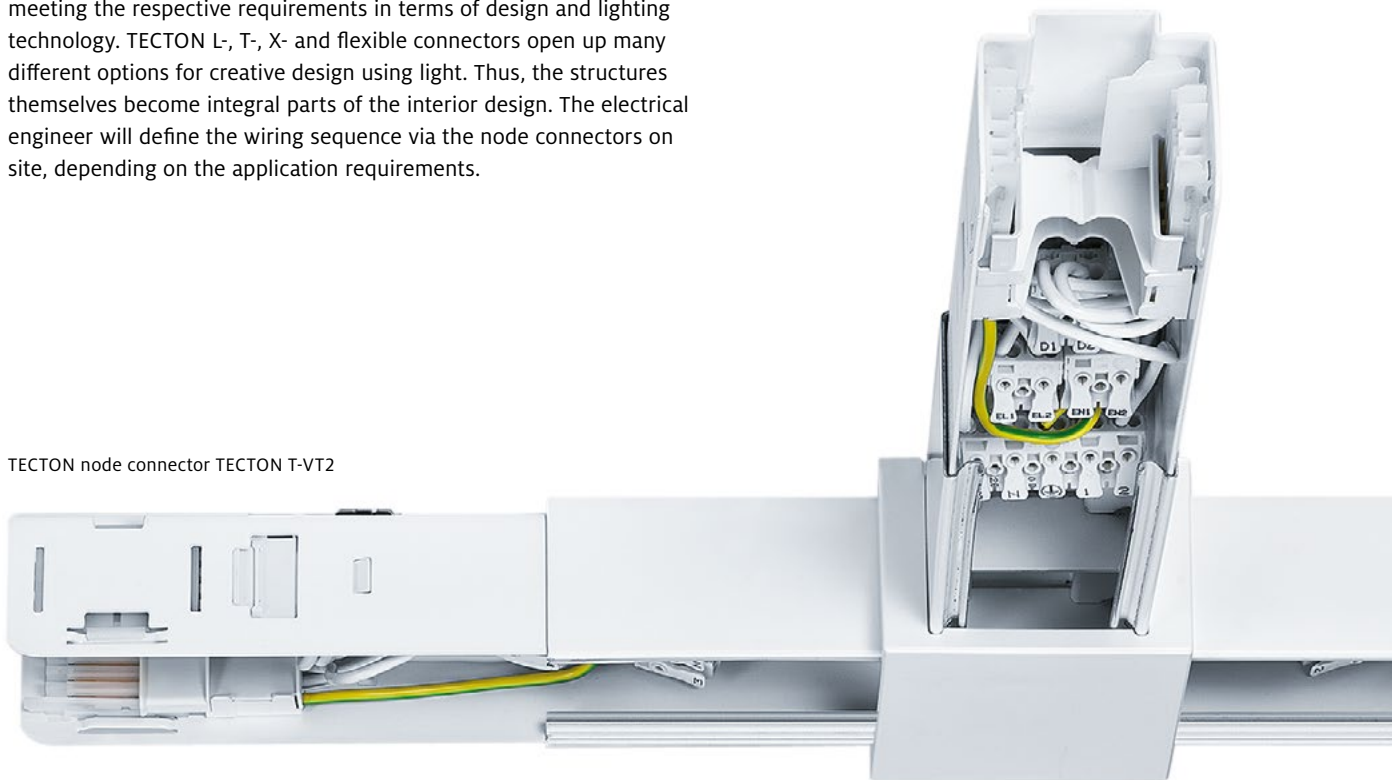

Wide range of trunking options

Design and implementation are made easy thanks to gradation in 0.5 m increments.

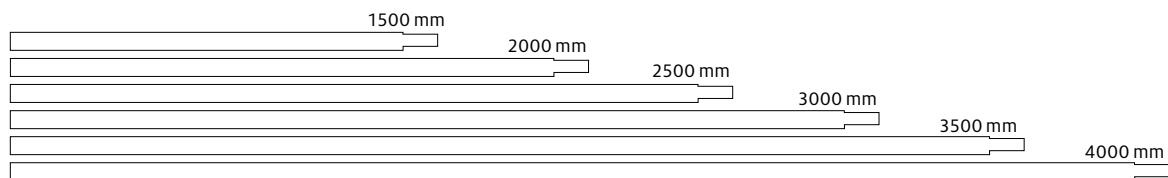

Trunking kit

Pre-assembled trunking unit which comprises T-trunking and TE electrical feed with end caps and protective covers.

5000 – 29 500 mm



Individual trunking units in three lengths

This means that individual luminaires have the same appearance as the continuous-row system.

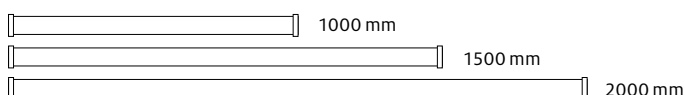

Blank end trunking

Can be cut to length by the customer, at the end of the continuous-row system (1000 oE).

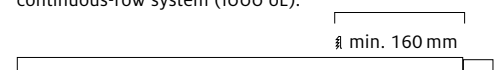

View from ABOVE

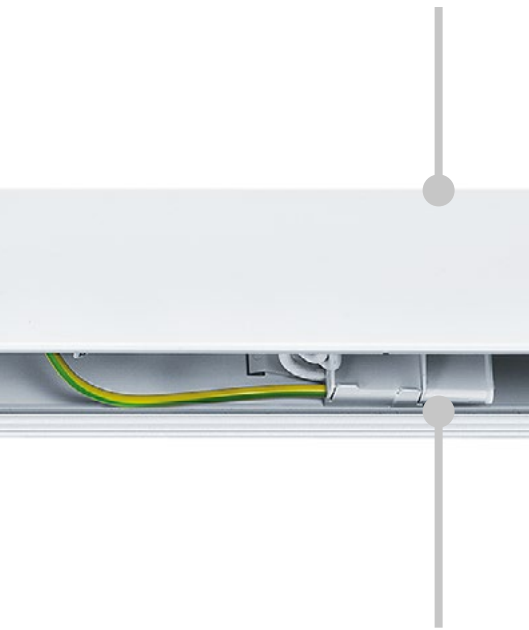

View from BELOW

View from above

L node connector

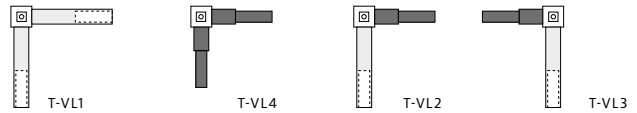

T node connector

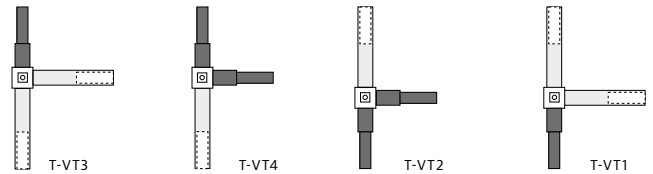

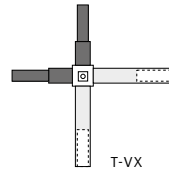

X node connector

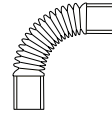

FLEX – flexible connector



For installation examples, see zumtobel.com/tecton

-  Fixing point
-  Electric feed
-  Feed-out

Calculating axial dimensions with node connectors

The axial dimension can be calculated very easily: two connectors together give 0.5 m. The trunking units are also provided in increments of 0.5 m. Therefore the axial dimension is always the trunking length plus 0.5 m.

Example: (view from above):

Axial dimension (mm) = length of trunking + 500 mm

Axial dimension (135 mm + 365 mm = 500 mm) + trunking T 1500 – T 4500

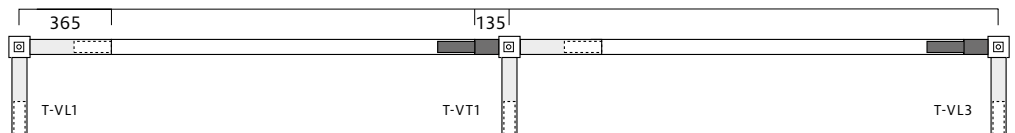

1 Trunking

Installation options

Possible feed-in and feed-out points

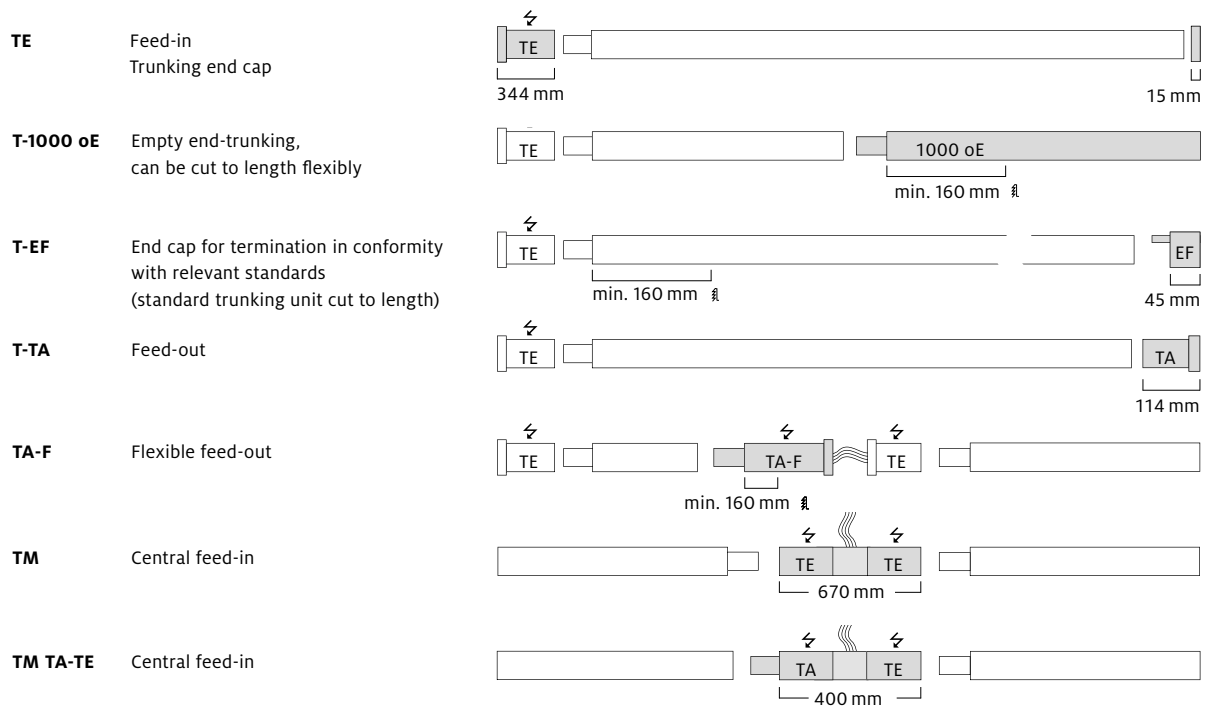

Possible feed-in and feed-out points

TECTON provides a wide variety of possible feed-in and feed-out points to cope with customer-specific requirements and conditions. An additional feed-in point is recommended for continuous-row systems which are longer than 50 m. TECTON central feed-ins are perfect for this purpose, especially since they do not disrupt the visual continuity of a continuous-row system.

Note: TECTON LED battens in lengths of 1000 mm, 1500 mm and 2000 mm fully conceal the input/output feeder (no emergency luminaires). This is not possible with spotlights, sensors and RESCLITE emergency luminaires due to the close rotary toggle spacing.

Fixing options

Cord suspension using Clix mechanism

Nothing is easier than fixing TECTON trunking. An ingeniously functional mounting bracket provides a clever link between the wall or ceiling and the trunking. The cord suspension can be fixed to the trunking without the use of any tool by exerting slight pressure, and it can also be moved as required. Pendant height adjustment is also entirely tool-free.



TECTON cord suspension | 1:1 scale

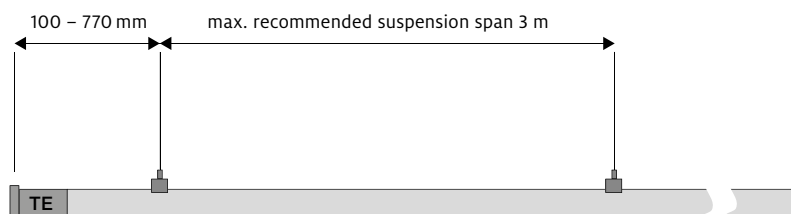

Suspension spans

A maximum suspension span of 3 m ensures quick and easy installation with fewer suspension points.

May be installed by qualified personnel only.

2 Continuous-row luminaire

Overview



TECTON with split-lens technology

For maximum efficiency with the best light quality



TECTON MIREL with MIREL lens optic

For high visual comfort



TECTON MPO with micro-prismatic optic

For demanding visual tasks



TECTON BASIC with diffuser optic

For basic lighting tasks

**HAWE Hydraulik, Kaufbeuren | DE**

Architecture: Barkow Leibinger Architekten, Berlin | DE

Lighting project design: Christian Kaindl Elektroplanung, Nandlstadt | DE

Different areas can come together in an industrial building – from production or storage areas and high-level racks, through offices, staff rooms and canteens, right through to underground car parks. This results in a multitude of requirements on the lighting, all of which are fully satisfied by the continuous-row lighting system. Consistent design is therefore combined with enormous flexibility.

2 Continuous-row luminaire

TECTON with split-lens technology and integrated smart location

TECTON has become an intelligent object: Without visible change and large effort, it can be integrated into the continuous-row system with split-lens technology beacons. The customer location is determined in real time in applications such as supermarkets. This opens a world of completely new service offers for the retailer – and shopping becomes an experience for the customers. They receive individual push notifications about offers or can simply navigate to their desired product. A subsequent analysis of the traffic paths supplies useful data that can help optimise the customer experience.

Why is it an advantage to integrate beacons into lighting?

- Beacons and light are installed together:
This simplifies handling, saves costs and creates a calm ceiling appearance.
- Wherever there is light, there is also room for a beacon:
The wiring cover is outstanding.
- Beacons are supplied with power via the luminaires:
If there are no batteries required, then they also do not have to be regularly replaced. This reduces the running costs.

“Thanks to virtual customer interaction, we are getting to know our customers and learning more about their individual wishes. With this knowledge, we will be able to increase satisfaction levels and thereby generate greater customer loyalty.”

Alain Lafforgue, CEO E.Leclerc Langon



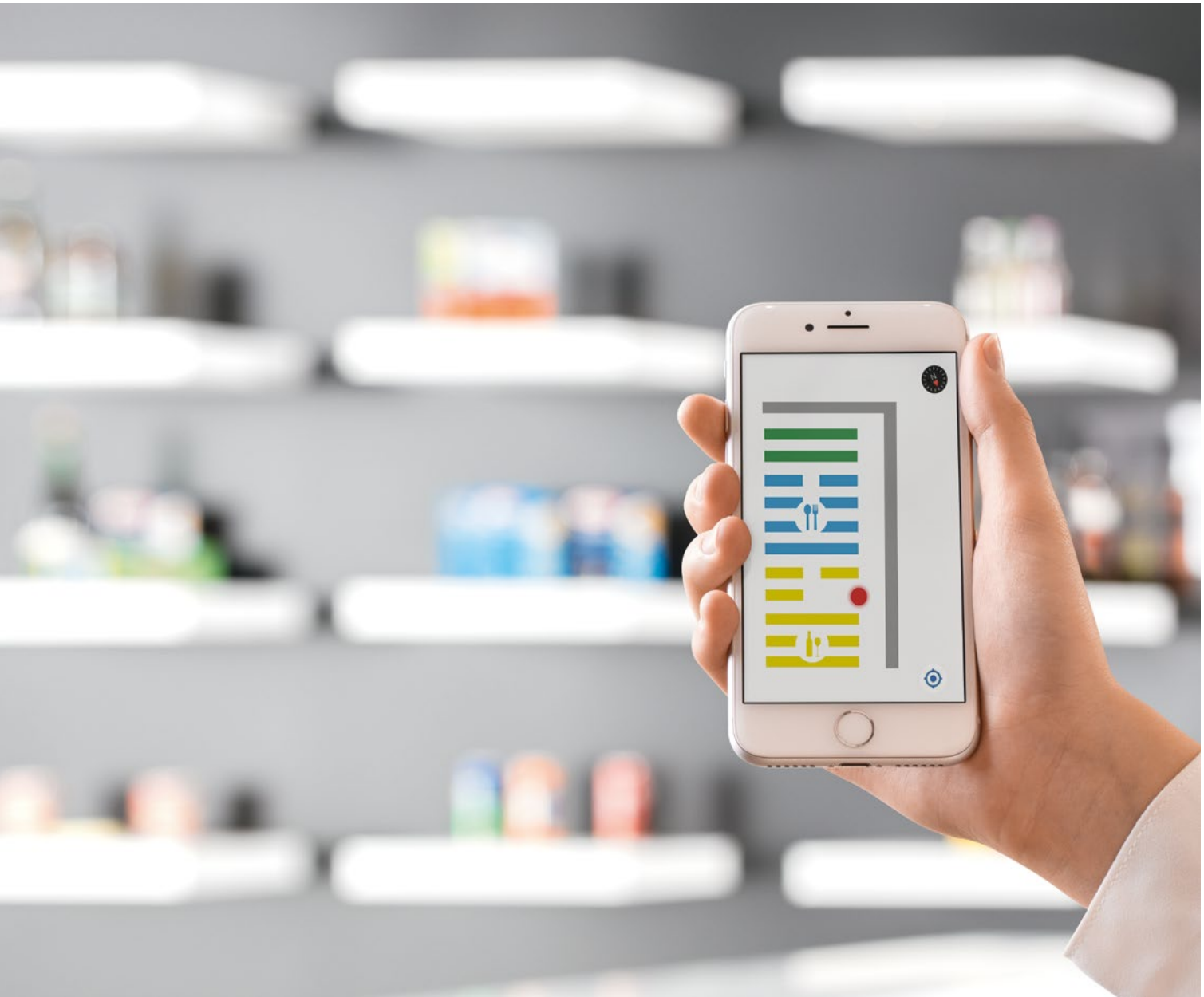

The leading chain in France, E.Leclerc, was one of the first companies to strike the way into the internet of things with smart TECTON luminaires. Already after a few weeks, the overwhelmingly positive response to the pilot project in the Langon hypermarket could be acquired in the numbers: Product recommendations sent via smartphone to the test subjects led to an increase in sales numbers compared to the previous year by up to 40 percent*.

Would you like to learn more about the project? Then send an email to zgs@zumtobelgroup.com. We will be glad to send you our insight paper "Digital Services in Retail".

Increase in sales number by up to

40%*

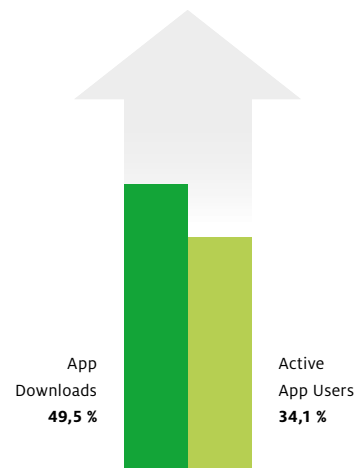

* The setup is done in close cooperation with the management team from E.Leclerc Langon. The customers were invited via various communication channels (email, SMS, etc.) to participate in the project, the offers were matched to the specific target groups. The timeframe for observation was January, which represents a neutral month for retail businesses.

2 Continuous-row luminaire

TECTON with split-lens technology



- 2 m LED batten luminaire cuts installation time by 40%
- IP50 for LED and optic as standard

Linear lighting: TECTON is a visual and functional unit. Compact and yet versatile, the linear luminaire emits pure calmness. This continuous-row system is free from joints, forming unbroken light lines that traverse the room. Pre-assembled end-caps reduce the number of components, supporting a solution that is both seamless and quick to install. With a luminaire efficiency of up to **168 lumens per watt**, TECTON also offers key economic benefits. Less maintenance work means fewer interruptions and reduced costs thanks to lower energy consumption. In addition, TECTON has an optimal colour rendering index of Ra 80 and an excellent service life – so that even after 50,000 hours of operation, 90 percent of the initial luminous flux will still be achieved.

Design TECTON: Zumtobel



module lengths

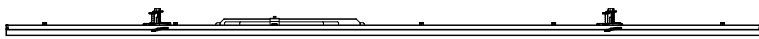

2000 mm, up to 16 000 lm

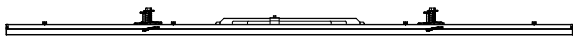

1500 mm, up to 12 000 lm



1000 mm, up to 8000 lm

2 Continuous-row luminaire

TECTON with split-lens technology

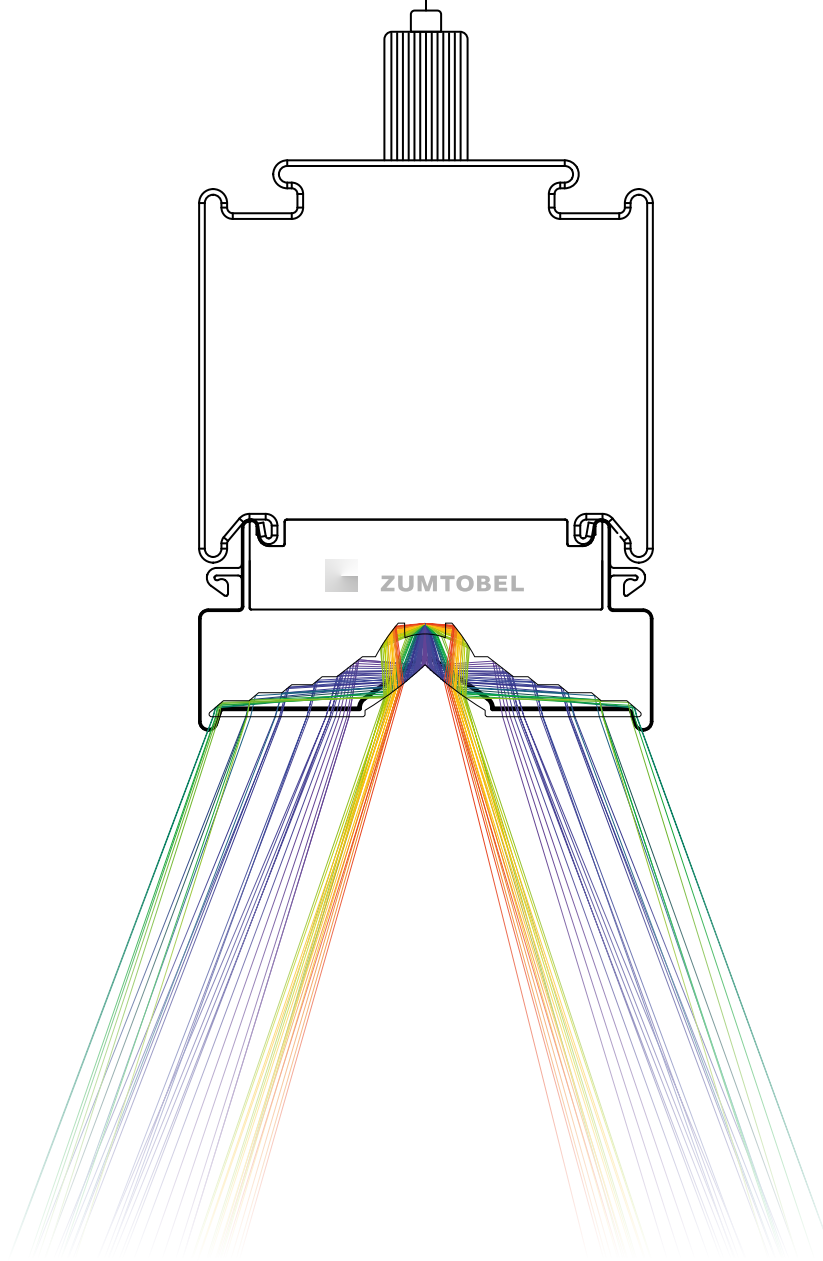

Split-lens technology

The split-lens directs the light in a targeted, efficient manner from the centre to the lateral areas. Accordingly, the lighting pressure in the middle is reduced, and the luminaire causes much less glare – without any negative effects on the light distribution curve. With the split-lens concept, all known beam patterns can be realised. The position of the LED remains visible, but in contrast to conventional lenses, the luminaire surface can be extended to the entire width, thus clearly gaining in homogeneity.

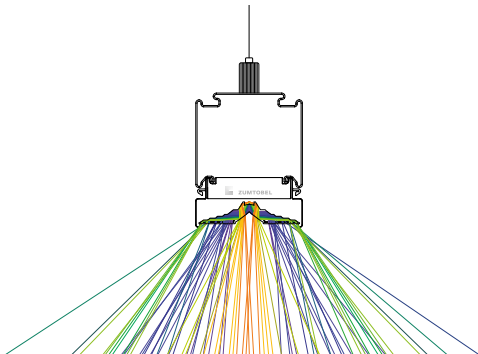

TECTON **wide beam**

The wide-beam optic is equally suitable for handling decorative as well as technical tasks. Its medium-wide light distribution is ideal for lighting shelf surfaces and aisle zones. It also illuminates surfaces without shelves, e.g. manufacturing areas, uniformly.

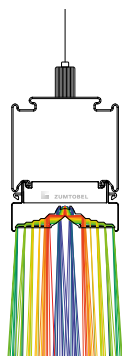

TECTON **narrow beam**

Specially developed for use in industrial and engineering applications, the narrow-beam optic ensures efficient, uniform illumination of the vertical fronts of shelving. With a maximum mounting height of around 18 m, it easily copes with medium and large room heights.

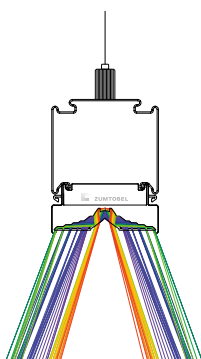

TECTON **shelf beam**

The shelf beam optic really comes into its own in presentation applications and retail spaces. Its symmetrical light distribution focuses on shelf surfaces; aisle zones are not as brightly lit. This way, customers' attention is directed to the goods that are on display.

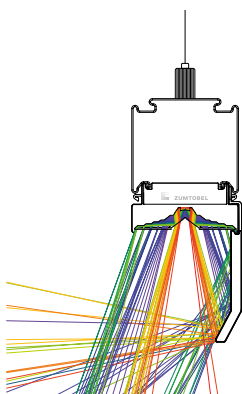

TECTON **wallwasher**

The wallwasher's asymmetric light distribution is specially designed for presentation and retail areas where there are one-sided shelf surfaces. An unobtrusive reflector that can be clicked into place quickly and without any tools presents goods in the right light.

2 Continuous-row luminaire

TECTON with split-lens technology

Typical applications

TECTON wide beam

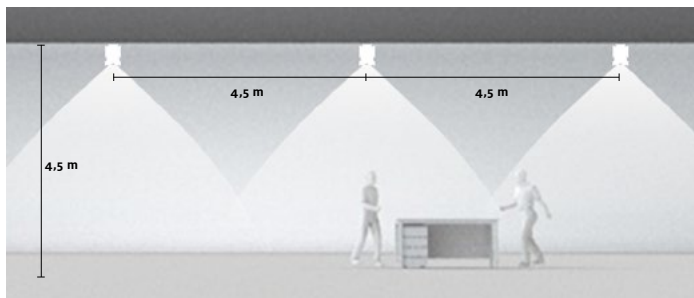

- Emphasis is placed on uniform illumination of manufacturing areas.
- The lighting solution can be designed and deployed regardless of the positioning of the respective machines and production areas.
- This allows subsequent repositioning of machines and production areas – without the need to modify the placement of luminaires.

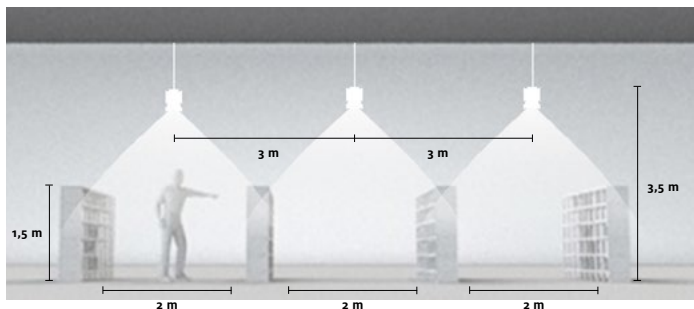

- Emphasis is placed on uniform illumination of aisle zones, shelf surfaces and larger surfaces.
- The lighting solution can be designed and deployed regardless of the positioning of the individual shelves.
- This allows subsequent alteration of the positions of shelves – without the need to modify the placement of luminaires.

TECTON narrow beam

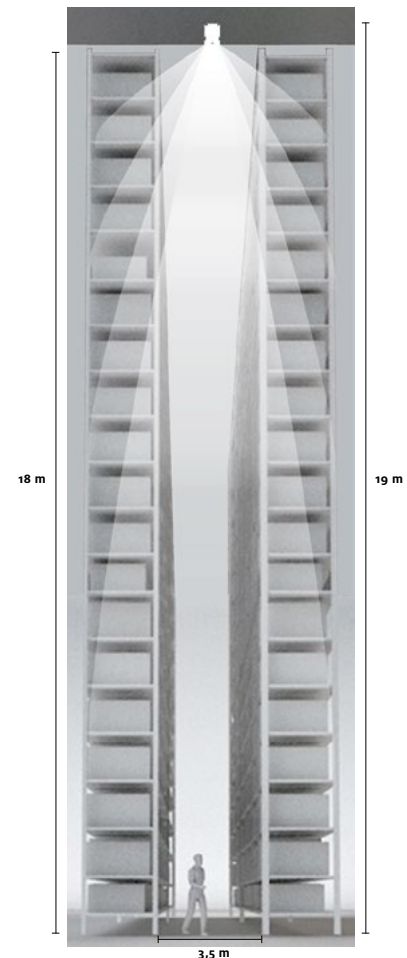

- Illuminance levels are optimised for medium to high shelving, emphasis is placed on aisle zones.
- The lighting solution is specifically designed and fitted to match the relevant shelving situation.
- This results in optimised lighting of the aisle zones in question.
- Uniform illumination of shelf surfaces.

TECTON shelf beam

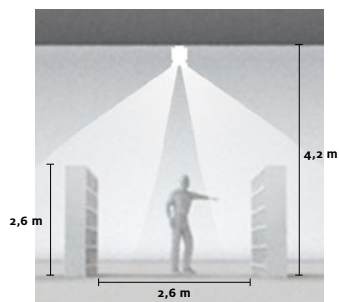

- Emphasis is placed on high-intensity, uniform illumination of one-sided shelf surfaces.
- The lighting solution is specifically designed and fitted to match the relevant shelving situation.
- An unobtrusive reflector is used to direct customers' attention directly to the shelf surfaces and products that are on display.

TECTON wallwasher

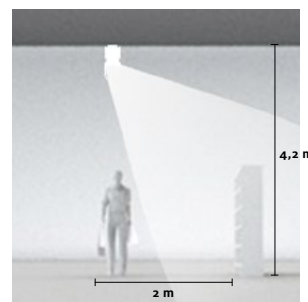

- Emphasis is placed on high-intensity, uniform illumination of shelf surfaces.
- The lighting solution is specifically designed and fitted to match the relevant shelving situation.
- This directs customers' attention directly to the shelf surfaces and products that are on display.

2 Continuous-row luminaire

TECTON with split-lens technology

Lumen packages

TECTON **High Output** and **Extreme High Output** allow for extended luminaire spacings on the continuous-row without reducing the quality or the amount of light, thanks to innovative lighting technology and high lumen packages. Even the distance between continuous-rows can be significantly increased.

In summary, fewer luminaires are required and the investment will pay off over a shorter period of time.

2-metre batten



High Efficiency		7 400 lumens (up to 167 lm/W)
High Output		10 500 lumens (up to 163 lm/W)
Extreme High Output		16 000 lumens (up to 154 lm/W)

1.5-metre batten



High Efficiency		5 500 lumens (up to 168 lm/W)
High Output		8 000 lumens (up to 162 lm/W)
Extreme High Output		12 000 lumens (up to 152 lm/W)

1-metre batten



High Efficiency		3 700 lumens (up to 160 lm/W)
High Output		5 200 lumens (up to 158 lm/W)
Extreme High Output		8 000 lumens (up to 145 lm/W)



Product features

LED perfection

With a colour rendering index of up to $R_a > 80$ and colour temperatures of 3000 K, 3500 K, 4000 K and 6500 K, TECTON demonstrates its excellent lighting quality

Chemical resistance

Only carefully selected materials with increased chemical resistance are used for all TECTON luminaires and components.

Selection of colours

All components in the TECTON continuous-row system, including accessories, are available in white, silver and black.



white silver black

Split-lens technology

Light that is dispersed directly within the split lens increases the homogeneity of the light-emitting panel, reducing glare and lighting pressure at the same time – in all four optics. This versatility and precision perfectly prepares the TECTON luminaire for the manifold tasks in industrial facilities and retail settings; their light control fully displays the benefits of LED by optimising horizontal and vertical illuminance levels and avoiding spill light.

As standard: IP50 and IK07 rating

In all optical variants, TECTON continuous-row luminaires dispose of the increased IP50 rating for LEDs and optics. Overlapping lenses and end pieces provide protection against soiling, eliminating cleaning effort and resulting in high IK07 mechanical stability. The thus extended maintenance cycle is very convenient, especially in the case of major exposure to soiling.

Quick installation

The continuous-row system is compatible with the entire TECTON product range. The luminaire and trunking are attached to each other quickly and securely thanks to a system that provides an audible and visible indication of locking. Familiar, tried-and-tested features, such as Plug & Play and no-tool installation, have been retained. TECTON is therefore also time-efficient.

TRIDONIC

Optional control gear

Upon request, TECTON continuous-row luminaires are available with industrial control gear from Tridonic, which offers an extremely long service life of 100 000 hours.

2 Continuous-row luminaire

TECTON with split-lens technology

2 m continuous-row luminaires



- up to 40 % shorter installation times
- up to 25 % fewer individual luminaires
- luminaire luminous flux levels of up to 16 000 lm

Regardless of conventional lamp lengths, TECTON is now available as a 2 m continuous-row luminaire. This reduces both the number of luminaires and the amount of work needed to install them. As compared to continuous-row luminaires with a length of 1.5 m, the new 2 m continuous-row luminaire also means less individual packaging and fewer parts at the installation site. Nevertheless, the 2 m unit comes with all the advantages of the conventional length: the lightweight continuous-row luminaire can still be mounted by one person.

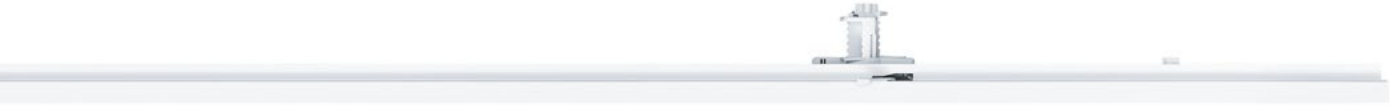

Example of a 24 m continuous-row luminaire

Lower investment and quicker installation: as compared to conventional continuous-row luminaires with a length of 1.5 m, the number of luminaires required when using 2 m continuous-row luminaires is reduced by some 25 per cent. Mounting can be accelerated by a full 40 per cent.

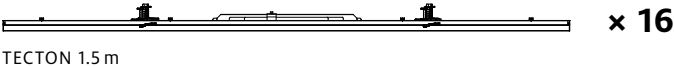

2 TECTON continuous-row luminaire

TECTON MIREL with MIREL lens optic

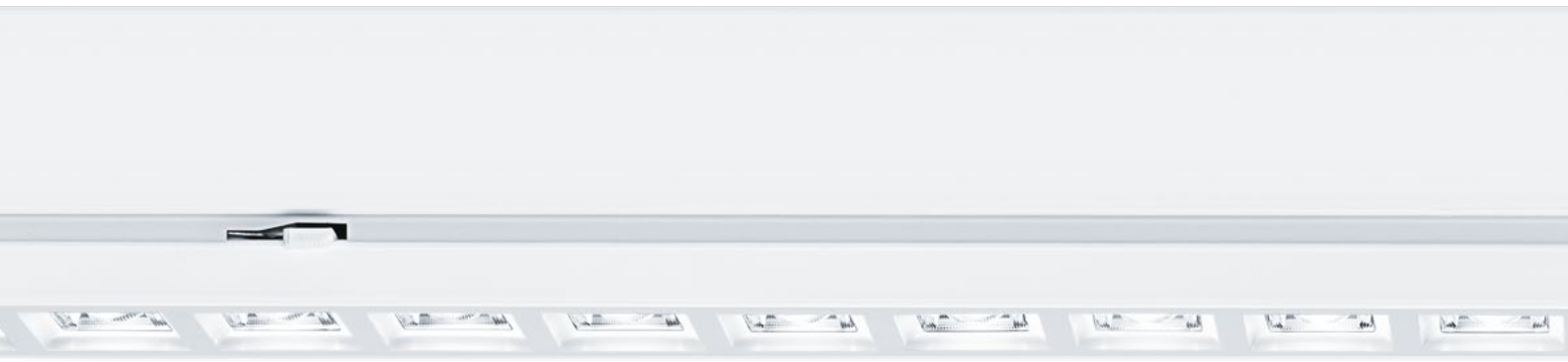

- ideal for education and office applications
(UGR < 19 and L65 < 3000 cd/m²)
- same slim design as the TECTON continuous-row luminaire
- as part of the TECTON product group, as flexible and comfortable to install as usual

TECTON MIREL with MIREL lens optic brings together the best of two worlds. While the slim continuous-row luminaire stands out with its enormous flexibility, the MIREL evolution office luminaire guarantees high visual comfort - even for demanding visual tasks. As a result, this continuous-row system satisfies a wide variety of requirements with a uniform design.

Factbox TECTON MIREL with MIREL lens optic

Glare control: UGR < 19 and L65 < 3000 cd/m² at 4000 lm
UGR < 19 at 5500 lm

Lumen packages: 4000 lm, 5500 lm

System efficiency: up to 144 lm/W

Colour temperature: 3000 K, 4000 K

Colour rendering: Ra 80

Service life:

50000 h at a reduction in luminous flux to 80%

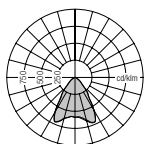

The visible LED lenses combine a directed light distribution with a brilliant appearance. The high lighting quality is manifested on the one hand by the good glare control and on the other in the batwing light distribution and high luminaire efficiency.

2 TECTON continuous-row luminaire

TECTON MPO with micro-prismatic optic



Workplaces for precision assembly laboratories, schools, supermarket check-outs and offices place higher demands on light quality. This is where LED technology can be combined with MPO optics to deliver tangible improvements. Micro-prisms free the 1.5-metre-long TECTON batten luminaires from disturbing reflections caused by visible light points and minimise the subjective glare sensitivity in the application. In this way, the strong light packages of 5500, 6500 and 8000 lumens gain a unique quality. With a colour temperature of 4000 Kelvin, a colour rendering index of Ra 80 and dimmable variants, TECTON with micro-prismatic optics represents a professional solution for specific application requirements. With a higher degree of protection and impact strength, the LED module and MPO optic are also suitable for industrial environments.

Design TECTON MPO with micro-prismatic optics: Zumtobel

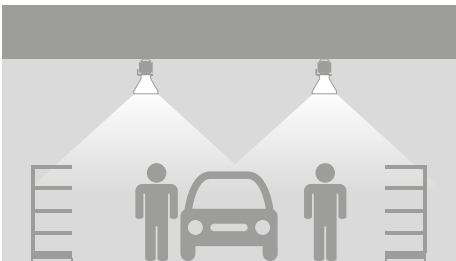

Non-reflective light for demanding workplaces in industry, for example, production lines for cars.

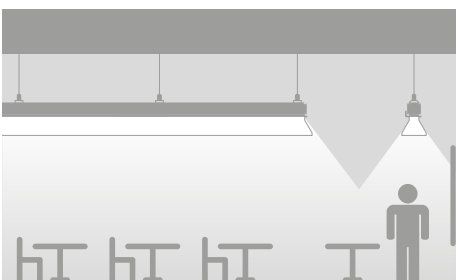

High-quality light and a comfortable atmosphere are rewarded in classrooms, for example, with a better ability to concentrate.

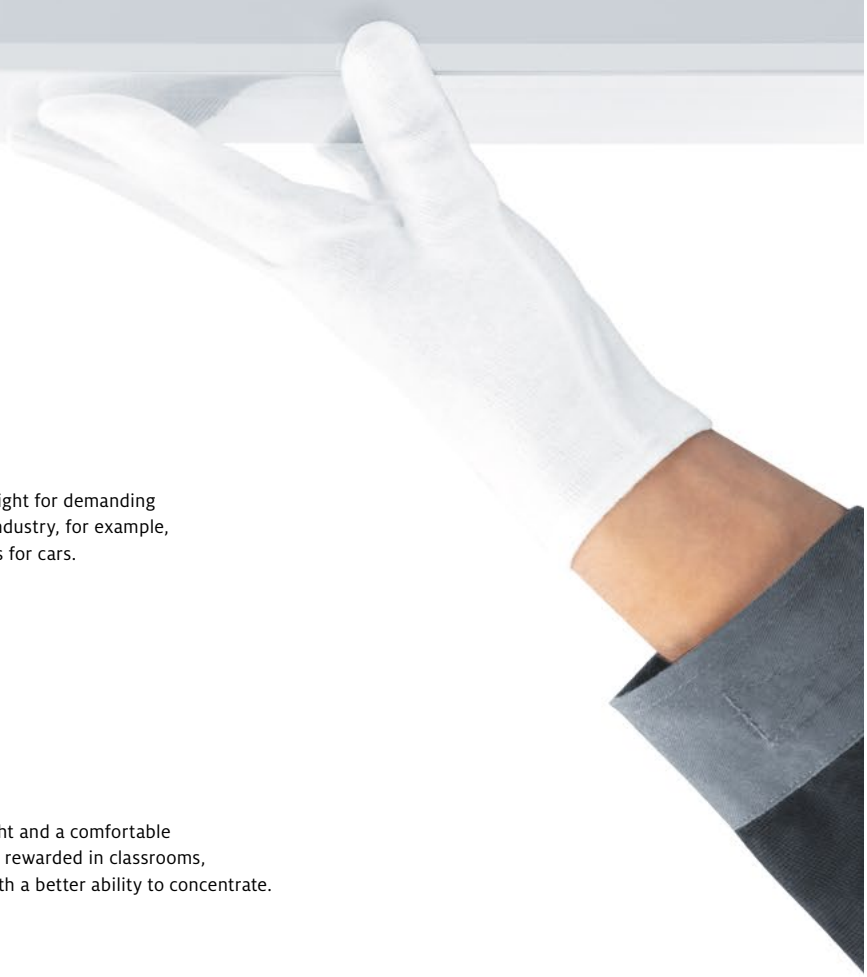

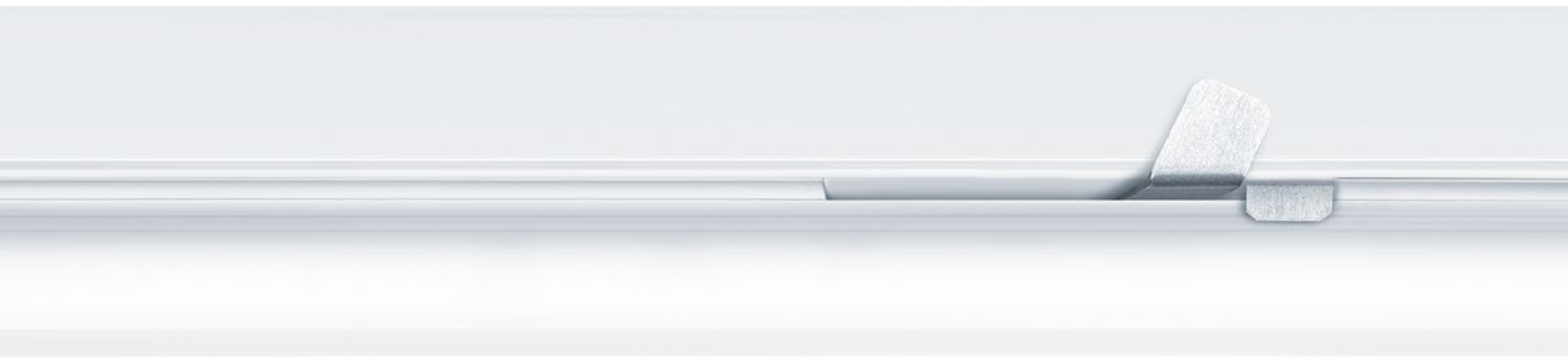

2 TECTON continuous-row luminaire

TECTON BASIC with diffuser optic



TECTON BASIC 1.5 metre

High Efficiency		5200 lumens (up to 140 lm/W)
High Output		8000 lumens (up to 137 lm/W)

TECTON BASIC with a diffuser optic was especially developed for locations with reduced requirements, enabling Zumtobel LED technology to be used in areas that previously had to make do with conventional solutions. As an LED batten luminaire that has been simplified in terms of both technology and optics, TECTON BASIC delivers a luminous flux of more than 8000 lm and an efficiency of around 140 lm/W, making it especially suitable for less complex lighting tasks in industry and retail. The luminaire is based on the tried-and-tested TECTON trunking, which ensures easy installation, flexible use and virtually unlimited options when it comes to upgrading.

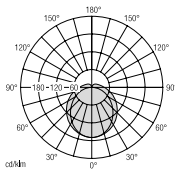

The TECTON BASIC continuous-row luminaire combines the tried-and-tested TECTON trunking and Zumtobel LED technology with an LED batten luminaire simplified in terms of optics for use in areas with reduced requirements.

3 Office and industrial luminaires

Luminaires for office applications



Complete office luminaires really demonstrate the advantages of TECTON mounting. Both the trunking and the luminaires are optimised for the integration of emergency lighting and lighting controls.

ECOOS

This office luminaire is based on a combination of micro-pyramidal optic and diffuser-pearl covering with a 360-degree light distribution.

MELLOW LIGHT evolution/infinity

Taking inspiration from nature, MELLOW LIGHT creates pleasantly bright spaces with little shadowing.

LINCOR

Thanks to the balanced mixture of direct and indirect light, this narrow light line promises perfect visual comfort for office workplaces.



ECOOS

Luminaire with micro-pyramidal optic MPO+



MELLOW LIGHT

Surface-mounted luminaire for office applications



LINCOR

Surface-mounted luminaire for office applications



3 Office and industrial luminaires

Luminaires for industrial applications

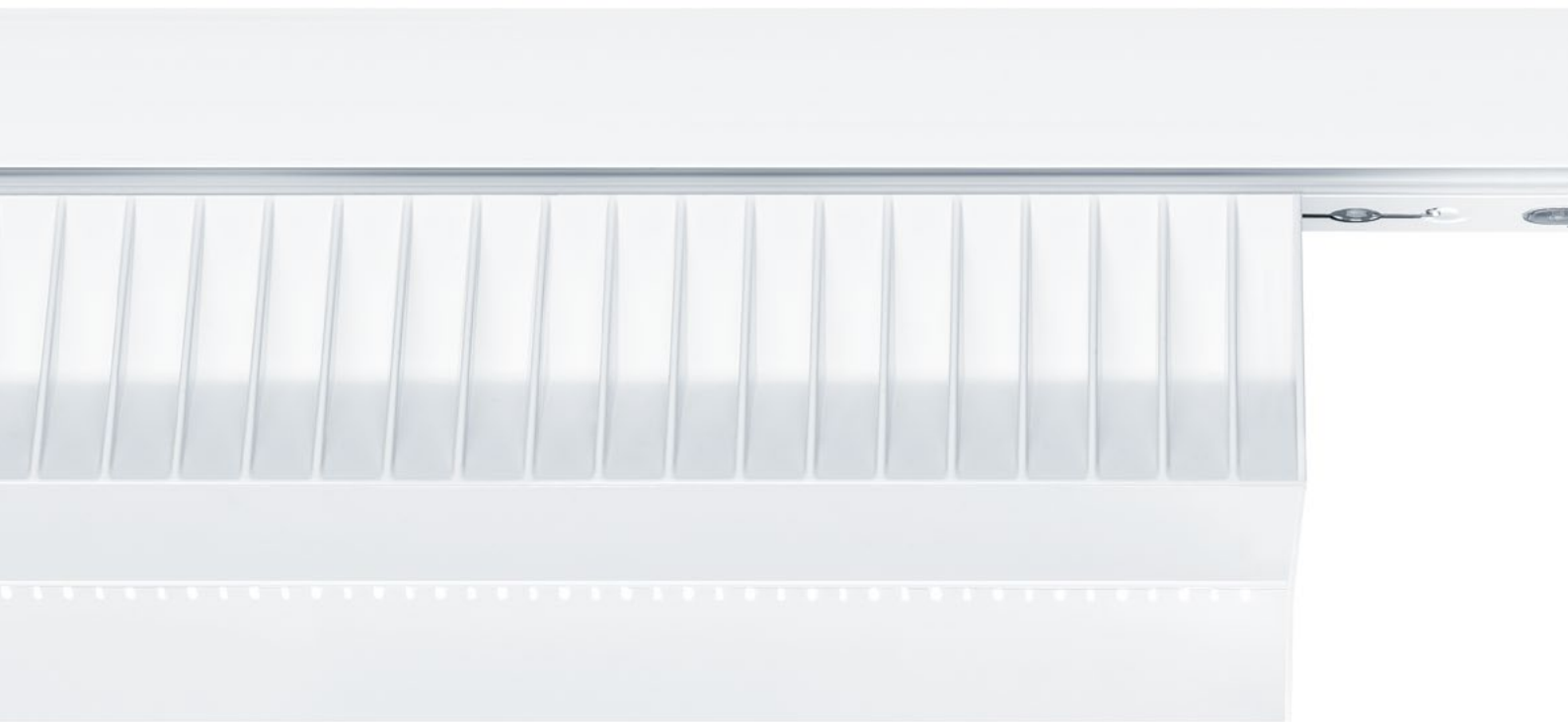

Working with TECTON means that a lighting solution remains permanently flexible. Already installed luminaires can be easily moved, while additional fittings and components simply have to be clicked into place at the required position.

CRAFT

Featuring unique thermal management, this compact high-bay luminaire is ideally equipped for industrial challenges.

PERLUCE

This moisture-proof luminaire combines protection classes IP50 and IP54 with a wide variety of optics and various shapes.



CRAFT
High-bay luminaire



PERLUCE
Moisture-proof luminaire



Easy installation is a major benefit of the light and compact CRAFT industrial luminaire.

4 Spotlights

Accent lighting

By allowing integration of Zumtobel's INTRO, VIVO, ONICO and FACTOR spotlight ranges, the TECTON continuous-row lighting system is able to create impressive lighting accents while fulfilling all other tasks as well. Thus, the lighting requirements for shops and retail spaces – ranging from uniform illumination to impressive lighting effects using high-precision reflectors – can be mastered with high efficiency. Here, too, installation is considerably facilitated by CLIX and plug-and-play mechanisms.



INTRO
spotlight



VIVO
spotlight



ONICO
spotlight



FACTOR
spotlight

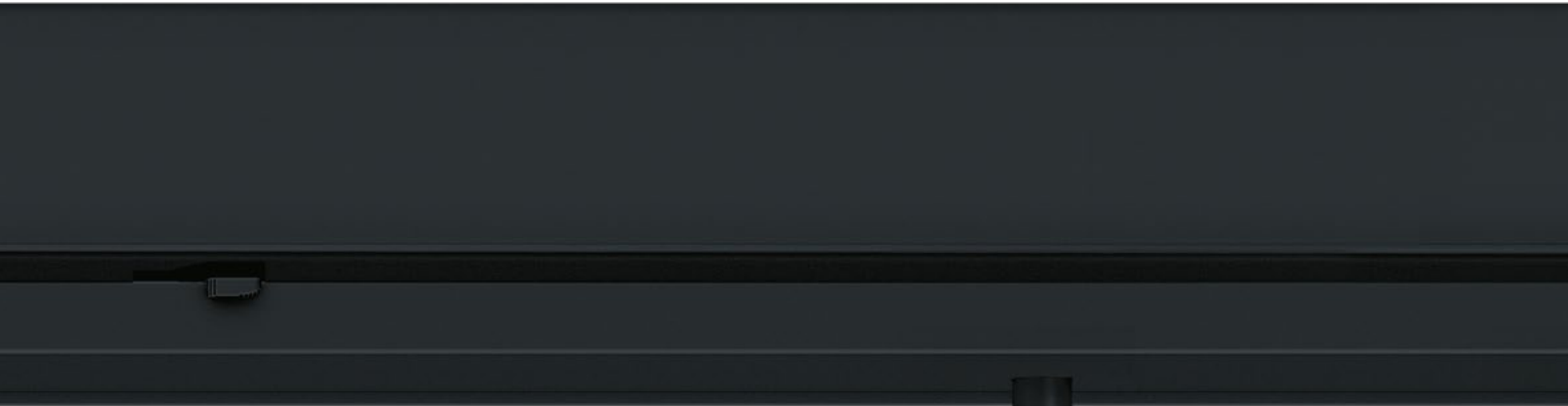

5 Emergency lighting

RESCLITE PRO emergency lighting



RESCLITE PRO offers the optimal solution for every application: compact and highly efficient emergency lighting that can be fully integrated into the TECTON continuous-row system without the need for tools.

RESCLITE PRO escape

Even long escape routes can be illuminated with just a few luminaires. The unique escape 90° optics aim the beam of light around the corner. This makes it possible to illuminate two right-angled intersecting corridors with a single emergency luminaire.

RESCLITE PRO antipanic

The wide-area illumination ensures good orientation in the room and helps minimise panic in an emergency – with a minimum number of luminaires.

RESCLITE PRO spot

In an emergency, a focused beam highlights essential objects, such as fire extinguishers.

RESCLITE PRO high ceiling

With escape-route and anti-panic lighting optimised for high rooms, even large halls can be ideally prepared for emergencies.

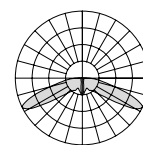

escape

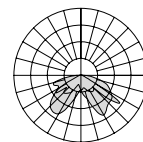

escape 90°

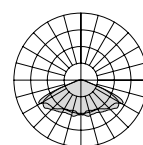

antipanic

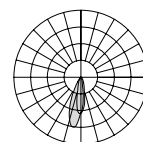

spot

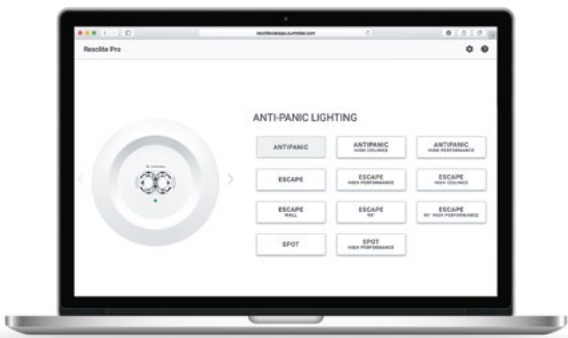

The RESCLITE PRO app provides a step-by-step guide to the planning and selection of emergency luminaires. resclitewebapp.zumtobel.com

5 Emergency lighting

Escape-sign luminaires



Even escape-sign luminaires can be perfectly integrated into the system via the TECTON trunking. This guarantees a high degree of efficiency and maximum safety in an emergency - and of course low installation effort.

PURESIGN 150

This slim luminaire conceals the most modern LED and lighting technology, which backlights the pictogram with optimum uniformity.

CROSSIGN 110/160

These all-round luminaires are ready to cope with the kind of tough ambient conditions often found in industry applications. The IP42-protected and IP54-protected luminaires are resistant against dirt and moisture.



PURESIGN 150



CROSSIGN 110/160



The web app for escape-sign luminaires simplifies both the planning and the selection of emergency solutions.

www.onlitewebapp.zumtobel.com



5 Emergency lighting

Integration of TECTON

Self-contained battery supply

In the case of self contained luminaires, the battery is fitted in the actual luminaire. Such luminaires operate as completely self-contained units and are easy to install. There is no need for expensive structural measures or fire-resistant wiring accessories. Self contained luminaires are rated E1D or E3D depending on whether they provide 1 hour or 3 hours of operating time.

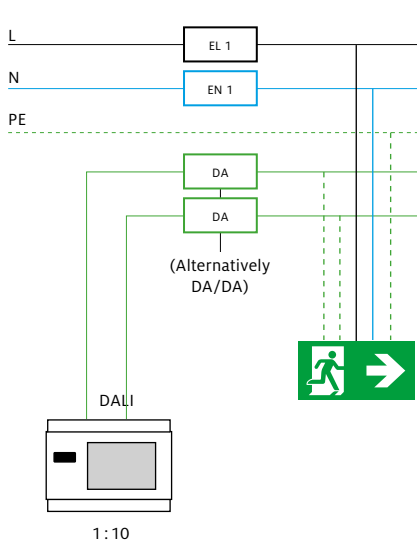

Function tests and annual system tests are performed automatically. The system is centrally monitored where an SB 128 Controller is used (optional).

SB 128 Single battery controller

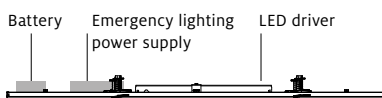

eBox Central battery system

The centrally supplied emergency lighting system is perfectly adjusted to the specifics of LED luminaires and features double energy efficiency: if energy-saving luminaires are connected, eBox scores high on low system output. The emergency lighting system supplies luminaires with a total installed load of 1500 W with power for one hour, luminaires with a total of 500 W for three hours. Several systems can be linked quite easily.

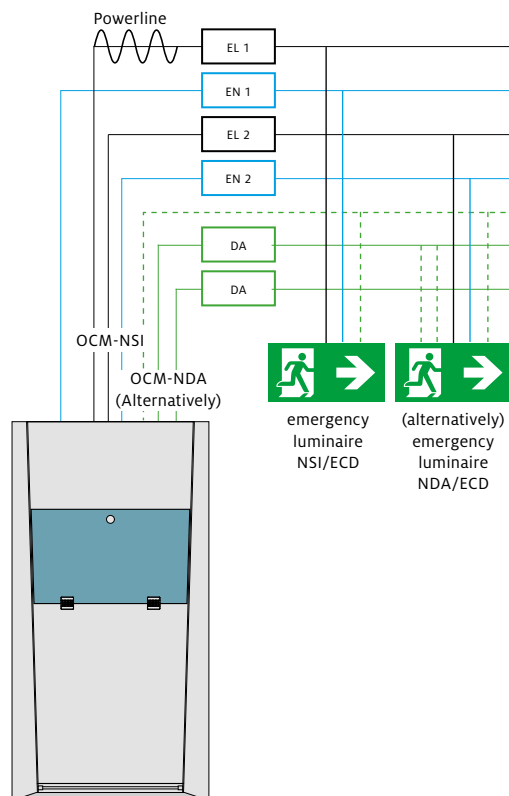

eBox Central battery system

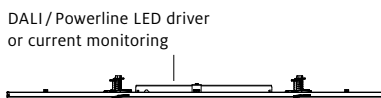

CPS Central battery system

Based on a modular system, each central battery system is perfectly customised to the client's requirements. The central battery system communicates via DALI. This way, each DALI luminaire can be used as a separately monitored emergency luminaire and be individually controlled. Other benefits include minimal maintenance effort and interference-free data communication.

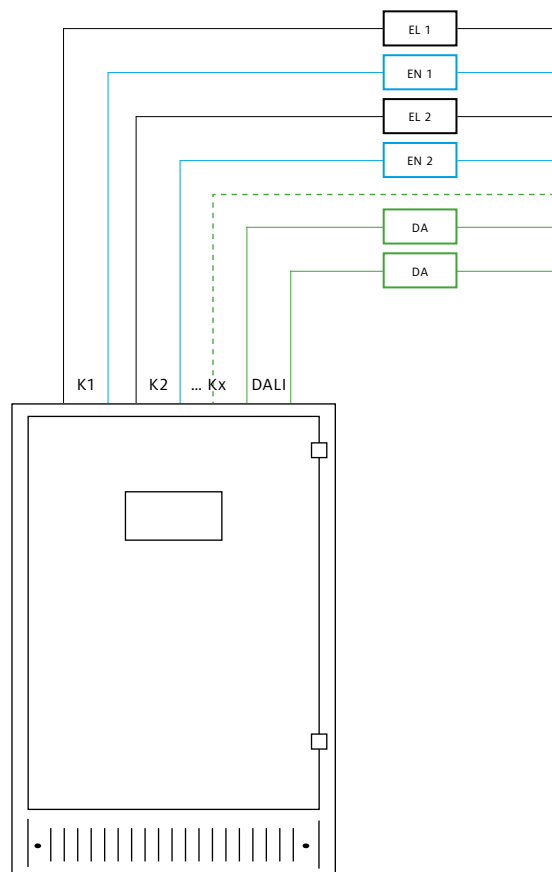

CPS Central battery system

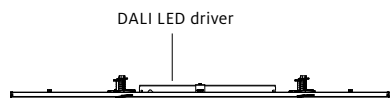

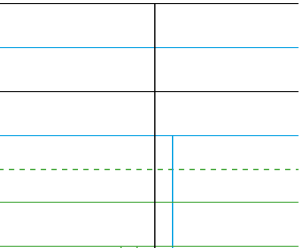

emergency luminaire
NDA/ECD



Increased safety with four circuits

Two independent circuits for emergency lighting (4 x 1.5 mm²)



PURESIGN 150



CROSSIGN 110



CROSSIGN 160

Escape-sign luminaires with TECTON adapter

Every escape-sign luminaire is available as a self-contained group battery or centrally powered version. These products are equipped with a TECTON adapter as standard. This ensures the TECTON installation concept is implemented consistently across the product range.

6 Lighting management

Sensors

Sensors are a key part of the TECTON system and form the basis for intelligent lighting management, reducing energy costs and increasing user comfort.

ED-EYE daylight sensor

This component continually records the amount of daylight entering the room. Based on these measurements, the lighting controls help achieve the desired luminous intensity by adding the required amount of artificial light.

PST motion sensor

This sensor detects movement in a defined space from heights of up to 16 metres. In this way, light is only used when and where it is really needed.

ED-SENS Multisensor

This multisensor supports presence detection and the integration of an infrared remote control for energy efficiency with a high degree of comfort.



ED-EYE
daylight sensor



PST
presence detector



ED-SENS
multisensor



6 Lighting management

Integration of TECTON

Plug & Play lighting management

DIMLITE

DIMLITE is a simple lighting management system, which nevertheless features the most important convenience and energy-saving functions and is ideal for small applications involving up to 100 DALI luminaires.

zumtobel.com/dimlite

System limitations:

- 25 DALI- or 50 DSI luminaires per channel

Energy saving:

- Uses indoor sensor to take daylight into account
- Presence detectors
- No-load disconnection of electronic ballasts by relay switching

Initial operation:

- Auto setup requires relatively little commissioning effort

Add-on functions:

- User-configurable lighting scenes
- CIRCLE control point and conventional momentary-action switches
- Switches

Lighting management for luminaires, blinds and emergency lighting

LITECOM

The scalable LITECOM system offers customised state-of-the-art bus technology for any size of installation. Lighting system and blinds are controlled on the basis of the current lighting and weather conditions. Energy consumption is sustainably optimised through daylight-based management, central time settings and presence detectors. LITECOM is suitable for installations with a medium number of DALI luminaires and blinds.

zumtobel.com/litecom

System limitations:

- max. 250 addresses per LITECOM CCD

Energy saving:

- Uses indoor light sensor to take account of daylight
- Automatic control of blinds
- Presence detectors
- Flexible calendar and timer functions

Initial operation:

- Commissioning via Zumtobel Service staff or wizard software

Notlichtintegration:

- eBox

Add-on functions:

- User-configurable lighting scenes
- Various local control options (CIRIA, CIRCLE, EnOcean radio etc.)
- Graphic user interface
- Touch panel integration
- Optional remote maintenance

LITENET

For installations with more than 250 addresses, the LITENET lighting management system must be used.

zumtobel.com/litenet

System limitations:

- Up to 500 "Economy topology" automation addresses
- Up to 2000 "Compact topology" automation addresses
- Up to 10 000 "Flexible topology" automation addresses

TECTON groups

1-4 (up to 25 x DALI or 50 x DSI luminaires per channel – can be extended by DALI-V or DSI-V)

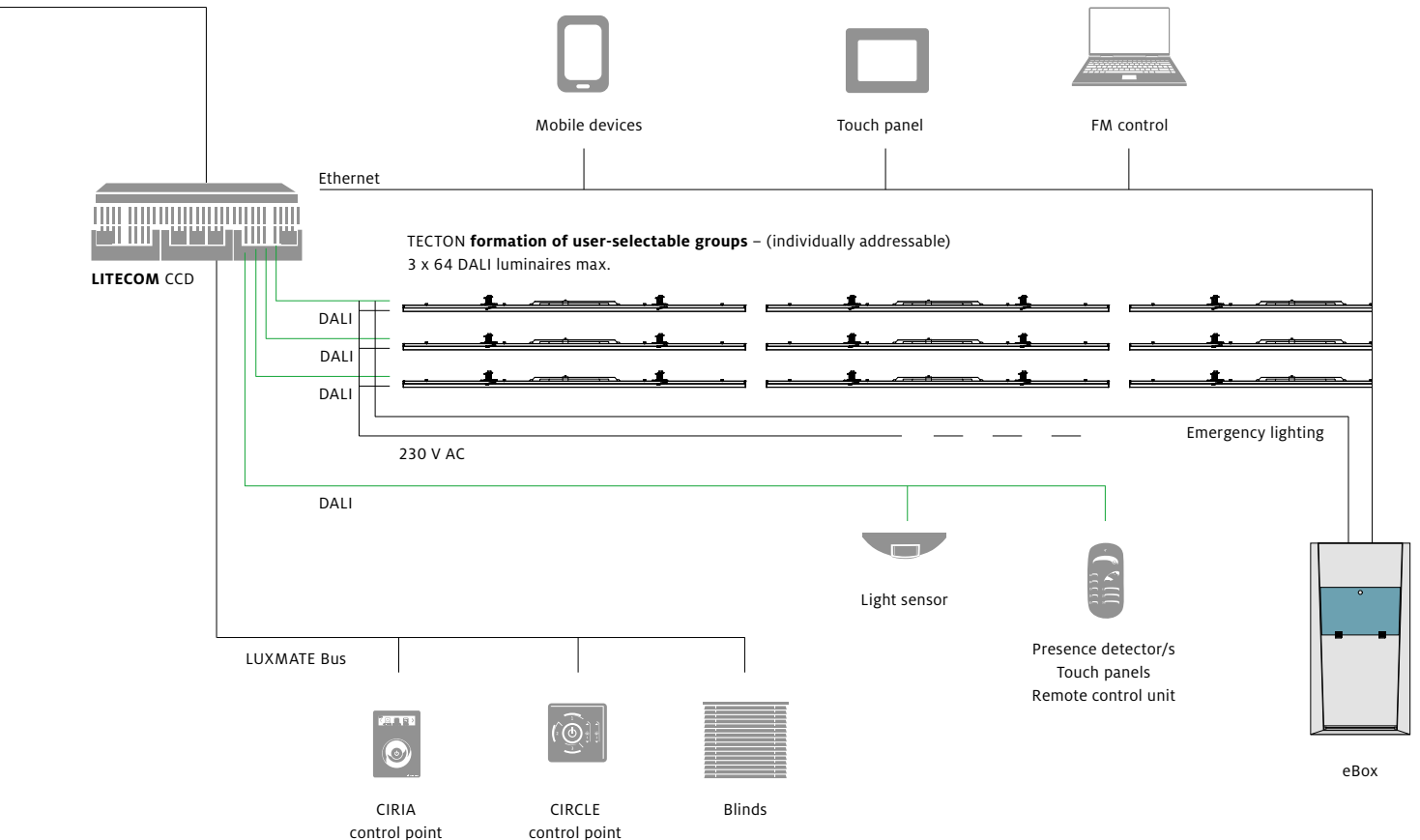
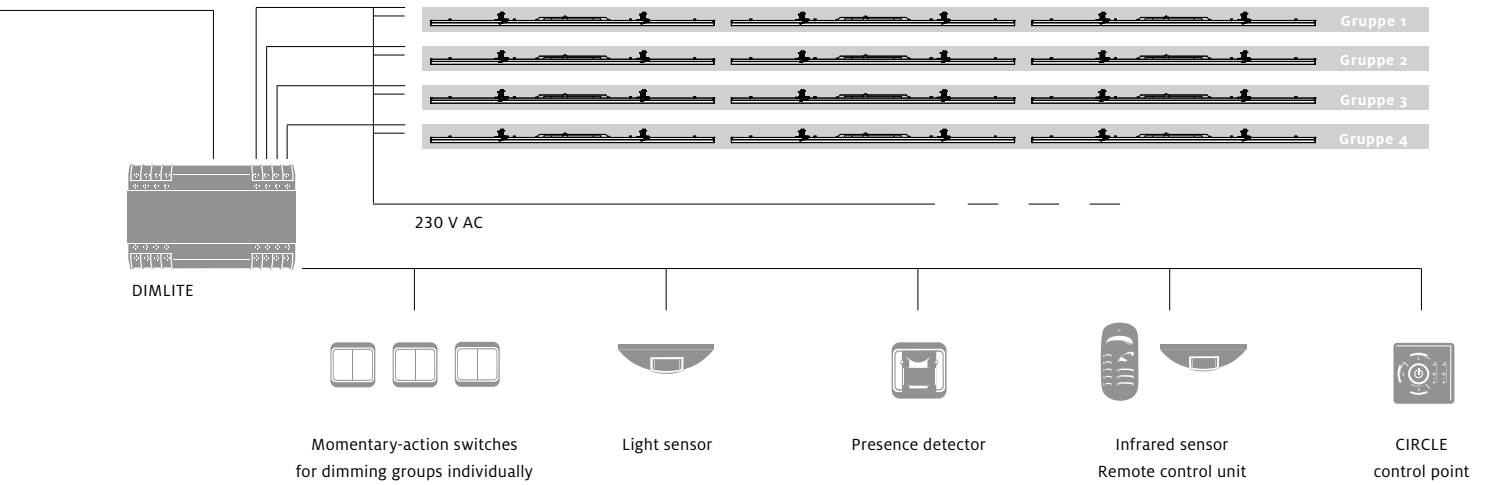

Installation

Saves time and money

15 m continuous-row system

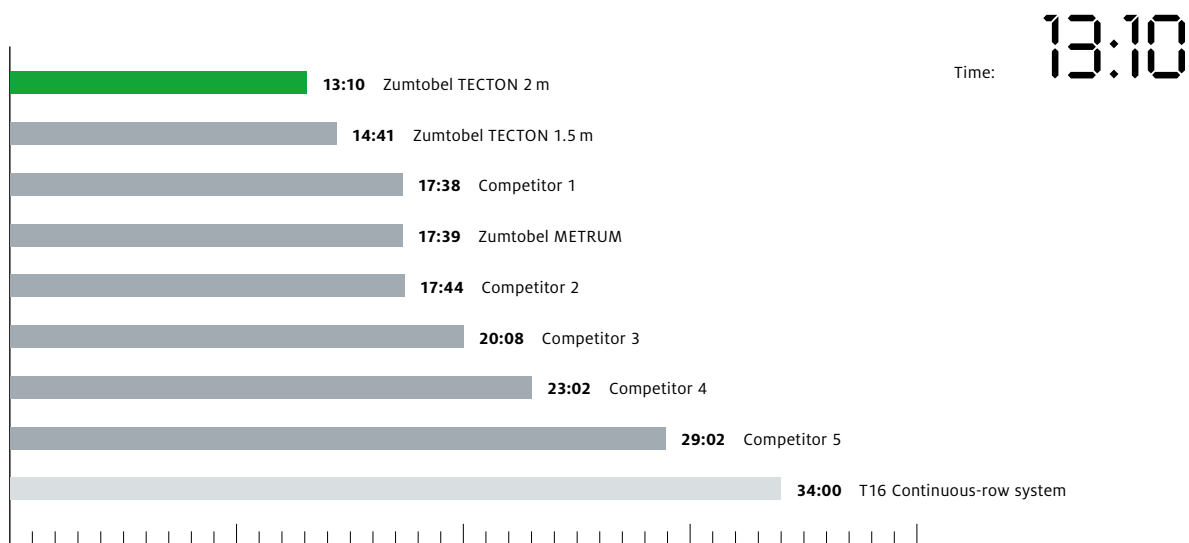

In a test organised to measure the installation time of eight different continuous-row systems (with a length of 15 metres), independent refaconsult GmbH found that TECTON can be installed considerably faster than comparable products. Time savings of up to 55 per cent certainly save a lot of money. Compared to conventional T16 solutions, 61 per cent of time can be saved on average with a TECTON solution. Moreover, TECTON already integrates emergency lighting circuits and DALI control lines.

Framework conditions test setup:

Length of continuous-row 15 m, ceiling height 3.7 m, height of continuous-row 3.2 m, 2 persons with ladders. The time indicated is for mounting excluding unpacking and excl. assembly of suspension systems (approx. 30 min).



One system – unlimited possibilities

Fitted with an 11-pole current-conducting section, TECTON solves not only all general and accent lighting tasks but also allows for emergency luminaires and sensors to be seamlessly integrated into the system.

Easy installation and flexibility

The complete continuous-row lighting system is characterised by very quick and easy installation. Only the trunking rails require an electrical feed, so the luminaires and sensors can simply be clicked into place – delivering absolute flexibility and ensuring that their position can be changed at any time.

Always up to date

The TECTON product portfolio is being continuously improved and extended. The installed trunking rail can be combined with the latest technology to create a truly future-proof solution.

Extensive solution competence

TECTON continuous-row luminaires with split-lens technology blend maximum efficiency with minimum glare, an impact resistance of IK07 and IP50 protection for the LED and the optic. Four different light distributions guarantee excellent flexibility.

100 per cent LED

Additional luminaires such as TECTON MIREL with MIREL lens optic, TECTON MPO with micro-prismatic optic and TECTON BASIC with diffuser optic, as well as the possibility to integrate other Zumtobel products, make TECTON a complete LED lighting solution.

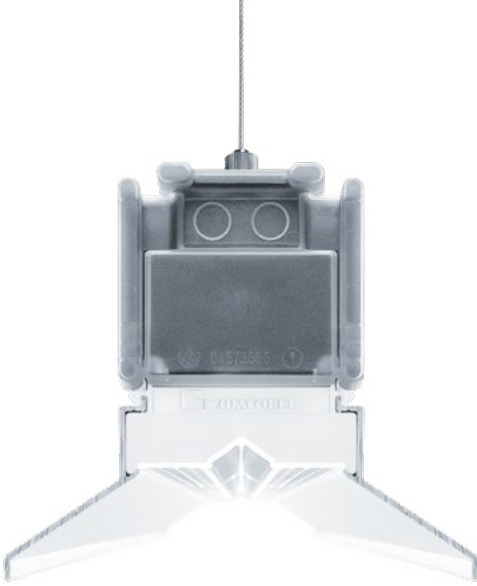

TECTON

The universal LED continuous-row system

Overview

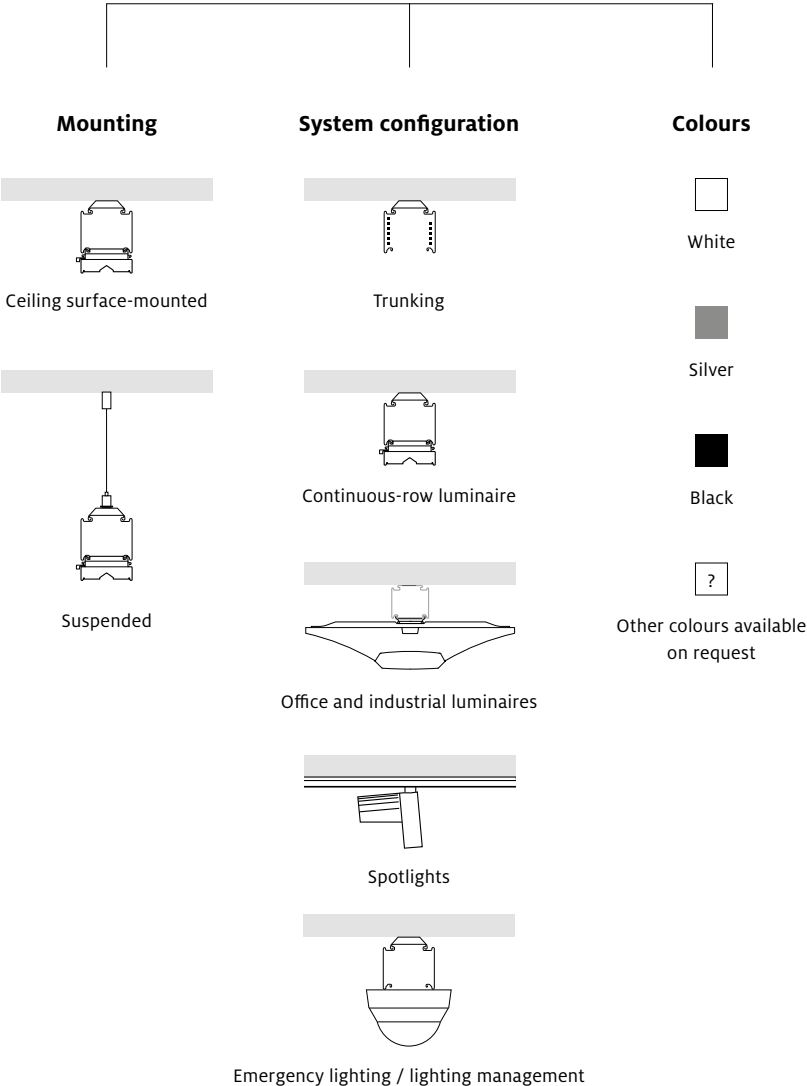

Zumtobel, a company of the Zumtobel Group, is an internationally leading supplier of integral lighting solutions for professional indoor and outdoor building lighting applications.



zumtobel.com/office



zumtobel.com/education



zumtobel.com/shop



zumtobel.com/hotel



zumtobel.com/culture



zumtobel.com/healthcare



zumtobel.com/industry

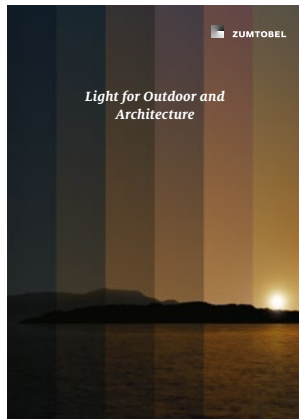

zumtobel.com/outdoor

- **Offices and Communication**
- **Education and Science**
- **Presentation and Retail**
- **Hotel and Wellness**
- **Art and Culture**
- **Health and Care**
- **Industry and Engineering**
- **Outdoor and Architecture**
- **Living**

We provide unique customer benefits by integrating technology, design, emotion and energy efficiency. We combine the best possible ergonomic lighting quality for an individual's well-being with the responsible use of energy resources. The company's own sales organisations in twenty countries, as well as commercial agencies in fifty other countries, form an international network of experts and design partners providing professional lighting consulting, design assistance and comprehensive services.

Lighting and sustainability

In line with our corporate philosophy "We want to use light to create worlds of experience, make work easier and improve communications and safety while remaining fully aware of our responsibility to the environment", Zumtobel offers energy-efficient high-quality products, while at the same time making sure that our production processes based on the considerate use of resources are environmentally compatible.

zumtobel.com/sustainability



Top quality – with a five-year guarantee.
As a globally leading luminaire manufacturer, Zumtobel provides a five year manufacturer's guarantee on all Zumtobel branded products in accordance with the terms of guarantee at zumtobel.com/guarantee.

Order no. 04 570 629-EN 11/18 © Zumtobel Lighting GmbH
Technical data was correct at time of going to press.
We reserve the right to make technical changes without notice. Please contact your local sales office for further information.





Tracks and spots

United Kingdom

ZG Lighting (UK) Limited
Chiltern Park
Chiltern Hill, Chalfont St. Peter
Buckinghamshire SL9 9FG
T +44/(0)1388 420042
info.uk@zumtobelgroup.com
zumtobel.co.uk

United Arab Emirates

Zumtobel Lighting GmbH (Branch)
4B Street, Al Quoz industrial area 1,
P.O.Box: 22672, Dubai,
United Arab Emirates
T +971 4 340 4646
info.ae@zumtobelgroup.com
zumtobel.ae

Slovak Republic

ZG Lighting Slovakia s.r.o.
Tomášikova 64
831 04 Bratislava
T +421 2 2030 0044
info.sk@zumtobelgroup.com
zumtobel.sk



Modular lighting systems

USA and Canada

Zumtobel Lighting Inc.
3300 Route 9W
Highland, NY 12528
T +1/845/691 6262
F +1/845/691 6289
info.us@zumtobelgroup.com
zumtobel.us

Qatar

ZG Lighting Trading WLL
Abdul Jaleel Business Centre,
Office No. 304, Najma Airport Road
P.O.Box: 6026
Doha, Qatar
T +974 4 432 1445
info.qa@zumtobelgroup.com
zumtobel.ae

Poland

ZG Lighting Polska Sp. z o.o.
Wołoska 9a
Platinum Business Park III
02-583 Warszawa
T +48 22 856 74 31
info.pl@zumtobelgroup.com
zumtobel.pl



Downlights

Australia

ZG Lighting Australia Pty. Ltd.
2/7 Millner Avenue,
Horsley Park, NSW 2175
T +61/1300 139 965
info.au@zumtobelgroup.com
zumtobel.com.au

Romania

Zumtobel Lighting Romania SRL
Radu Greceanu Street, no. 2,
Ground Floor, sector 1
012225 Bucharest
T +40 31225 38 01
F +40 31225 38 04
info.ro@zumtobelgroup.com
zumtobel.com

Slovenia

ZG Lighting d.o.o.
Štukljeva cesta 46
1000 Ljubljana
T +386/(1) 5609 820
F +386/(1) 5609 866
info.si@zumtobelgroup.com
zumtobel.si



Recessed luminaires

New Zealand

ZG Lighting (NZ) Limited
27 Jomac Place,
Avondale, Auckland 1026
PO Box 71134, Rosebank,
Auckland 1348
T 0800 800 834
T +64/(9) 828 7155
F +64/(9) 820 7591
info.nz@zumtobelgroup.com
zumtobel.co.nz

Hungary

ZG Lighting Hungary Kft.
Váci út 49
1134 Budapest
T +36/(1) 450 2490
F +36/(1) 350 0829
info.hu@zumtobelgroup.com
zumtobel.hu

Russia

ZG Svet JSC
Official office Zumtobel Group
Nizhniy Susalniy pereulok,
5/19, office 405
105064 Moscow
T +7/(495) 981 35 41
T +7/(812) 604 02 60
info.ru@zumtobelgroup.com
zumtobel.ru



Surface-mounted and pendant luminaires

China

Thorn Lighting (Guangzhou) Limited
12A Lian Yun Road
Eastern Section,
GETDD, Guangzhou
510530, P.R. China
T +86(20)2232 6000
Sales Hotline: 400 8080 195
info.cn@zumtobelgroup.com
zumtobel.cn

Croatia

ZG Lighting d.o.o.
Ulica Petra Hektorovića 2
10000 Zagreb
T +385/(1) 64 04 080
F +385/(1) 64 04 090
info.hr@zumtobelgroup.com

Norway

ZG Lighting Norway AS
Bygdøy allé 4
0257 Oslo
T +47 22 54 72 00
info.no@zumtobelgroup.com
zumtobel.no



Free-standing and wall-mounted luminaires

Hong Kong

ZG Lighting Hong Kong Ltd.
Unit 503 – 508, 5/F, Building 16W,
Phase 3, Hong Kong Science Park,
New Territories, Hong Kong
T +852/(0)2578 4303
F +852/(0)2887 0247
info.hk@zumtobelgroup.com

Bosnia and Herzegovina

ZG Lighting d.o.o.
Predstavništvo u BiH
Zmaja od Bosne 7
71000 Sarajevo
T +387 33 590 463
info.ba@zumtobelgroup.com

Sweden

ZG Lighting Nordic AB
Hyllie Boulevard 10b
215 32 Malmö
T +46 649 20 00
info.se@zumtobelgroup.com
zumtobel.se



Continuous-row systems and individual batten luminaires

Singapore

ZG Lighting Singapore Pte. Ltd.
158 Kallang Way # 06-01/02
Singapore 349245
T +65/6844 5800
F +65/6745 7707
info.sg@zumtobelgroup.com

Serbia

ZG Lighting d.o.o.
Beton hala – Karadorđeva 2-4
11000 Belgrade
M+381 69 54 44 802
info.rs@zumtobelgroup.com

Denmark

ZG Lighting Denmark A/S
Stamholmen 155, 5. sal
2650 Hvidovre
T +45 35 43 70 00
info.dk@zumtobelgroup.com
zumtobel.dk



High-bay luminaires

Czech Republic

ZG Lighting Czech Republic s.r.o.
Jankovcova 2
Praha 7
170 00 Praha
T +420 266 782 200
F +420 266 782 201
info.cz@zumtobelgroup.com
zumtobel.cz

Headquarters

Zumtobel Lighting GmbH
Schweizer Strasse 30
Postfach 72
6851 Dornbirn, AUSTRIA
T +43/(0)5572/390-0
info@zumtobel.info



Luminaires with extra protection



Façade, media and outdoor luminaires



Lighting management systems



Emergency lighting

The Light.